



higher education
& training

Department:
Higher Education and Training
REPUBLIC OF SOUTH AFRICA

T700(E)(A3)T

NATIONAL CERTIFICATE

FITTING AND MACHINING THEORY N2

(11022032)

3 April 2019 (X-Paper)

09:00–12:00

Calculators and drawing instruments may be used.

This question paper consists of 11 pages and 1 formula sheet.

DEPARTMENT OF HIGHER EDUCATION AND TRAINING
REPUBLIC OF SOUTH AFRICA
NATIONAL CERTIFICATE
FITTING AND MACHINING THEORY N2
TIME: 3 HOURS
MARKS: 100

NOTE: If you answer more than the required number of questions, only the required number of questions will be marked. All work you do not want to be marked must be clearly crossed out.

INSTRUCTIONS AND INFORMATION

1. Answer ALL the questions in SECTION A, except for QUESTION 1 where you should answer either QUESTION 1.1 OR QUESTION 1.2.
 2. Answer any TWO of the three questions in SECTION B.
 3. Read ALL the questions carefully.
 4. Number the answers according to the numbering system used in this question paper.
 5. Write neatly and legibly.
-

SECTION A

Answer only QUESTION 1.1 OR QUESTION 1.2.

QUESTION 1: OCCUPATIONAL SAFETY

NOTE: Answer ONLY QUESTION 1.1 OR QUESTION 1.2.

1.1 Indicate whether the following statements are TRUE or FALSE. Choose the answer and write only 'True' or 'False' next to the question number (1.1.1–1.1.5) in your ANSWER BOOK.

1.1.1 The standard colour of oxygen hoses are black and acetylene hoses are red. 

1.1.2 All shafts and spindle ends which project more than half of its diameter must be completely enclosed.

1.1.3 Light belts may be shifted on the coned pulley of machine tools to alter the working speed whilst the machine is in motion.

1.1.4 V-belts that are cracked or swollen may be cut and rejoined for use.

1.1.5 Electrical switches must be labeled to indicate the machine or equipment that they control.

(5 × 1)

[5]

OR

1.2  Indicate whether the following statements are TRUE or FALSE. Choose the answer and write only 'True' or 'False' next to the question number (1.2.1–1.2.5) in your ANSWER BOOK.

1.2.1 All waste material in a mine must be put in the container provided next to the switchgear.

1.2.2 On completion of an underground welding task, an examination must be carried out by a competent person to ensure that no fire will result.

1.2.3 Calcium carbide may be taken underground in a watertight receptacle approved by the regional manager. 

1.2.4 First aid certificates must be renewed after a period of 5 years.

1.2.5 Only lights or lamps approved by the Director General shall be allowed into the workings of any fiery mine.

(5 × 1)

[5]

QUESTION 2: COUPLINGS

- 2.1 Explain the function of a coupling. (2)
- 2.2 State the groups into which the following couplings fall:
- 2.2.1 Raffard coupling
-  2.2.2 Fluid drive coupling
- 2.2.3 Universal coupling
- 2.2.4 Resilient coupling
- (4 × 1) (4)
[6]

QUESTION 3: LIMITS AND FITS

- 3.1 List FOUR values of the ISO system of limits and fits. (4)
- 3.2 A coupling must have a shrink fit onto a shaft. The dimensions of the hole and shaft are as follows: 

SHAFT: $\begin{matrix} +0.25\text{mm} \\ \text{Ø}85 \\ +0.10\text{mm} \end{matrix}$

COUPLING: $\begin{matrix} +0.10\text{mm} \\ \text{Ø}85 \\ -0.00\text{mm} \end{matrix}$

Calculate the following:

- 3.2.1 The lower limit of the shaft
- 3.2.2 The higher limit of the coupling
- 3.2.3 The tolerance on the shaft 
- (3 × 1) (3)
[7]

QUESTION 4: BEARINGS

- 4.1 Name the TWO types of rolling contacts that occur in rolling bearings. (2)
- 4.2 FIGURE 1 below shows a diagram of a bearing. Identify the bearing loads labeled A, B and C. Write only the answer next to the LETTER (A–C) in the ANSWER BOOK.

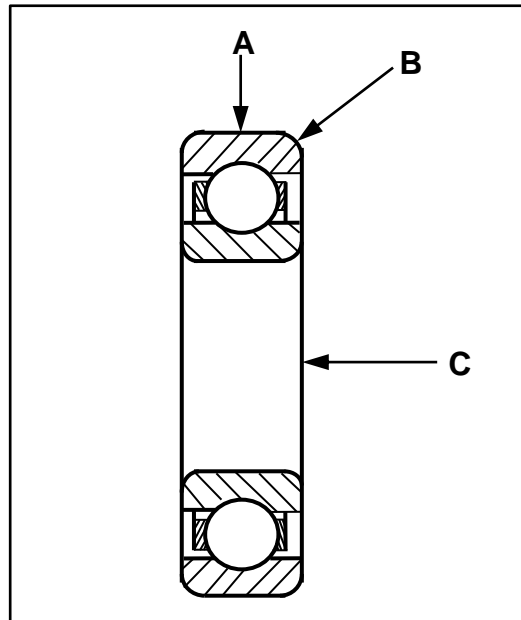

FIGURE 1

(3)
[5]

QUESTION 5: LUBRICATION AND VALVES

- 5.1 Name the THREE main types of lubricants. (3)
- 5.2 State TWO functions of valves used in fluid power systems. (2)
- 5.3 Explain the function of a safety valve in a fluid system. (1)

[6]

QUESTION 6: PACKING, STUFFING BOXES AND JOINTS AND WATER PIPE SYSTEMS

- 6.1 Describe, in FIVE steps, how to pack a stuffing box. (5)
- 6.2 List FOUR disadvantages of plastic piping. (4)

[9]

QUESTION 7: PUMPS

FIGURE 2 below shows the operation of a plunger pump.

Study the diagram and answer the questions.

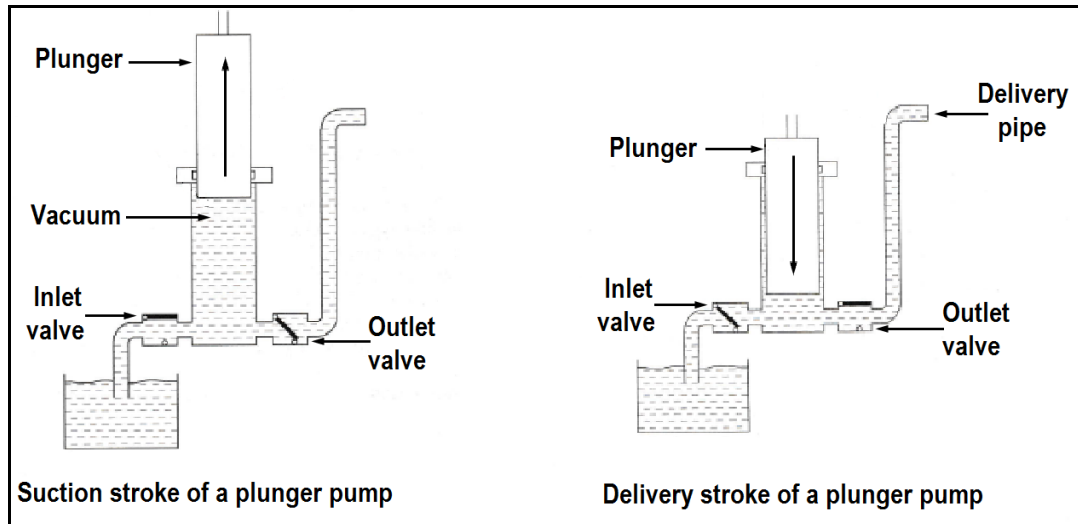

FIGURE 2

- 7.1 Explain the operation of the plunger pump. (4)
- 7.2 State the type of displacement that occurs in this pump. (1)
- 7.3 Give a reason for your answer in QUESTION 7.2. (1)

[6]



QUESTION 8: COMPRESSORS

- 8.1 Name TWO types of reciprocating piston compressors used in industry. (2)
- 8.2 What is the purpose of an intercooler in a *multi-stage centrifugal compressor*. (2)

[4]

QUESTION 9: V-BELTS, GEAR DRIVES, CHAIN DRIVES AND REDUCTION GEARBOXES

9.1 FIGURE 3 below shows a cross-sectional view of a V-belt. Name the parts labelled A, B and C. Write only the answer next to the letter (A–C) in the ANSWER BOOK.

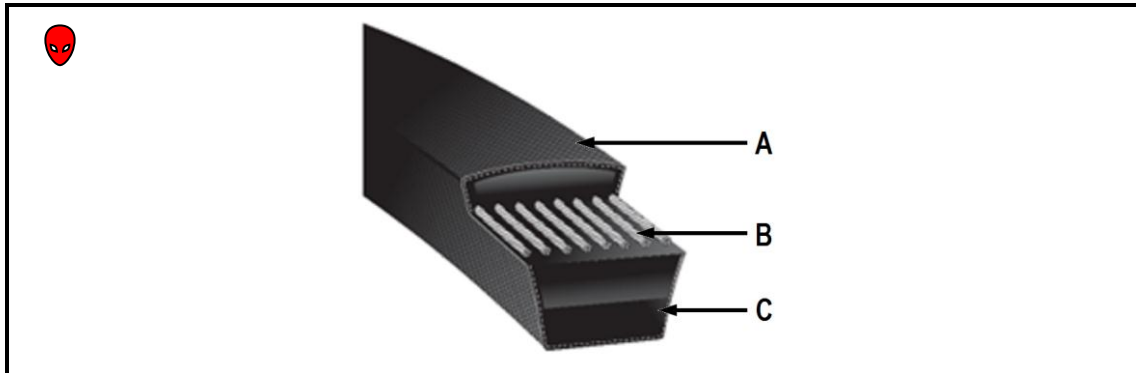

FIGURE 3

(3)

9.2 List THREE safety precautions to be taken when working with gear drives.

(3)

9.3 State THREE advantages of chain drives over gear drives.

(3)

9.4 Give a reason for the use of double reduction gearing when requiring the following: 

9.4.1 A high output speed

9.4.2 A high output load

(2 × 1)

(2)

9.5 What is the name given to the gear fitted to the output shaft of the gearbox?

(1)



[12]

TOTAL SECTION A:

60

SECTION B

Answer only TWO questions in this section.

QUESTION 10: HYDRAULICS AND PNEUMATICS

10.1 Explain how the hydraulic fluid is used to perform the following functions in a hydraulic system:



10.1.1 Power transmission

10.1.2 Lubrication

10.1.3 Cooling

(3 × 1) (3)

10.2 Identify the ISO hydraulic symbols below. Write only the answer next to the question number (10.2.1–10.2.5) in the ANSWER BOOK.

10.2.1



10.2.2



10.2.3

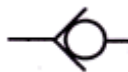

10.2.4

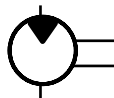

10.2.5



(5 × 1) (5)

10.3 Explain the functions of each of the following hydraulic components:

10.3.1 Pressure relief valve

10.3.2 Control valve





(2 × 1) (2)

10.4 Name the TWO most important factors in the functioning of a pneumatic system.

(2)

- 10.5 Make neat, freehand sketches of the ISO symbols representing the following pneumatic components:
- 10.5.1 Compressor 
- 10.5.2 Air receiver
- 10.5.3 Pneumatic motor
- (3 × 1) (3)
- 10.6 State the main difference between a *hydraulic system* and a *pneumatic system* (2)
- 10.7 List the THREE checks to be done on hoses when maintaining a pneumatic system. (3)
- [20]**

QUESTION 11: CENTRE LATHES

- 11.1 State the function of a lathe mandrel. (1)
- 11.2 State TWO causes of a long, slender shaft bending when not using a lathe steady.  (2)
- 11.3 State TWO ways of cutting a taper on the lathe. (2)
- 11.4 A circular shaft with an outside diameter of 85 mm must be machined with a two-start square thread of 12 mm pitch.
- Calculate the following:
- 11.4.1 The lead of the thread (1)
- 11.4.2 The mean diameter of the thread (2)
- 11.4.3 The helix angle of the thread  (2)
- 11.5 The cutting speed for a cast iron bar of 65 mm diameter is 22 m/min.
- Calculate the rotational speed of the spindle in revolutions per minute. (3)
- 11.6 A shaft with a length of 600 mm and a diameter of 90 mm is to be machined on a lathe. The cutting speed is 36 m/min and the machine feed is set at 0,75 mm/revolution.
- Calculate the time required for the machining process in minutes and seconds.  (5)
- 11.7 Name the TWO types of programming applicable to CNC lathes. (2)
- [20]**

QUESTION 12: MILLING MACHINES AND SURFACE GRINDERS

12.1 FIGURE 4 shows pictures of milling cutters. Name the milling cutters writing only the answer next to the letter (A–E) in the ANSWER BOOK.

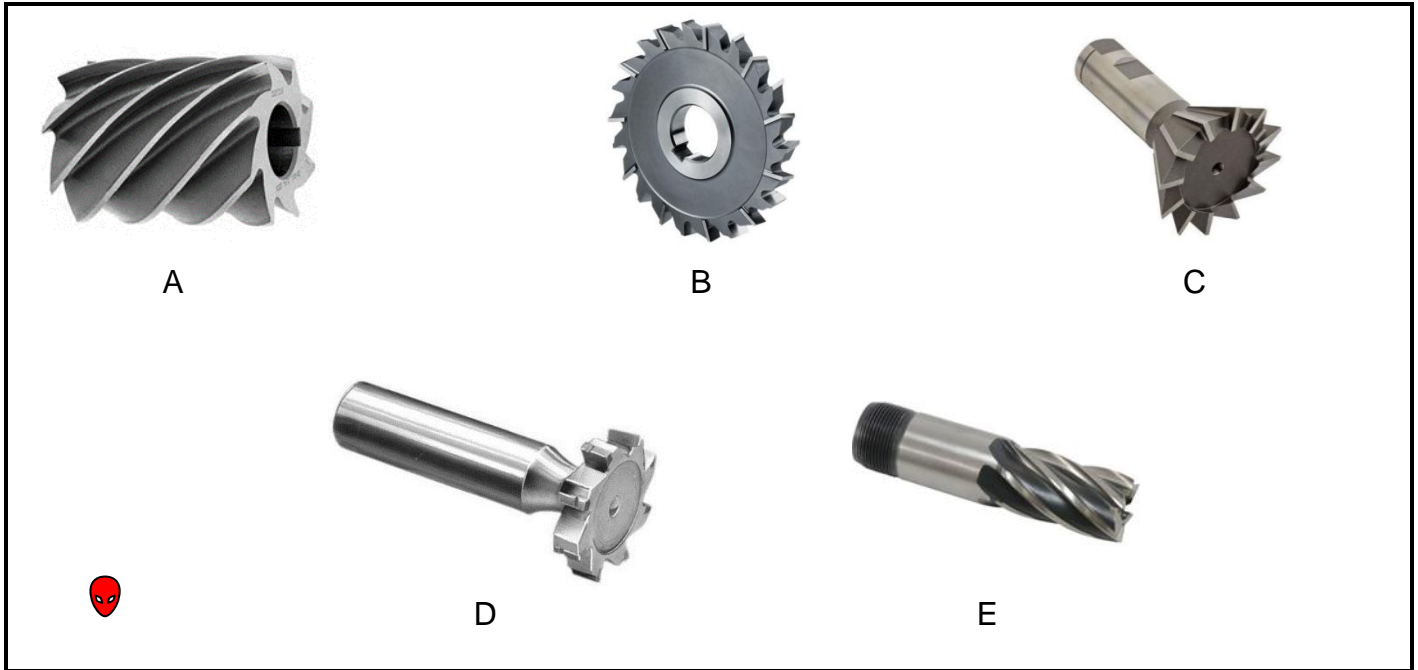

FIGURE 4

(5)

12.2 A milling machine is used to cut 12 evenly spaced grooves around a shaft.

Calculate the required indexing using a Cincinnati dividing head.

NB: Use only side 2 on this index plate.

THE CINCINNATI DIVIDING HEAD INDEX PLATE											
Side 1	24	25	28	30	34	37	38	39	41	42	43
Side 2	46	47	49	51	53	54	57	58	59	62	66

(5)

12.3 A 60 mm diameter cutter with 12 teeth and a cutting speed of 35 m/min has a feed of 0,09 per tooth. 

Calculate the feed in mm/min.

(5)

12.4 FIGURE 5 shows a diagram of a machine.

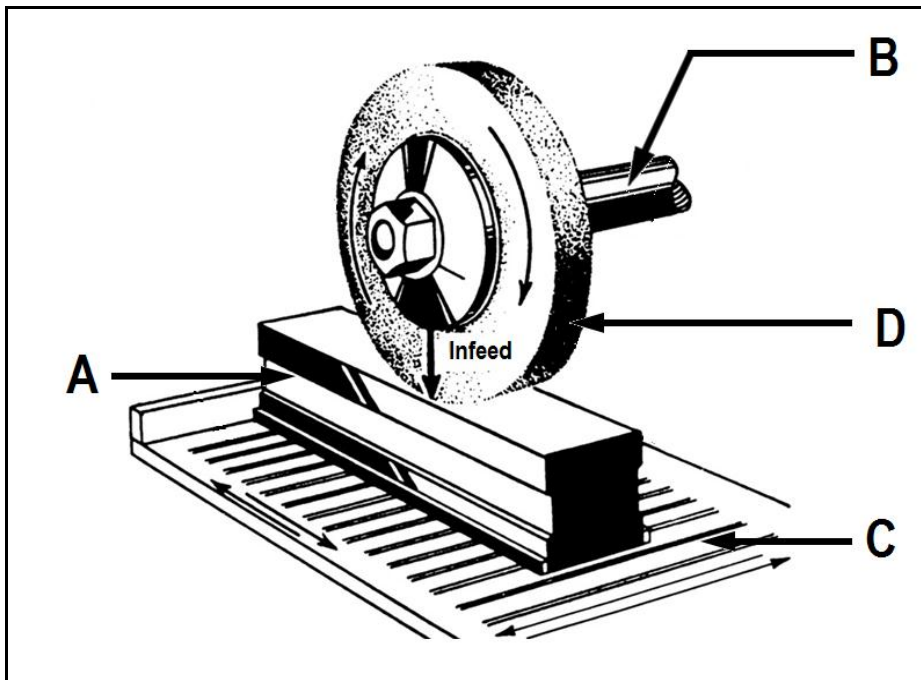



FIGURE 4

- 12.4.1 Name the machine shown in FIGURE 5  (1)
- 12.4.2 Identify the parts labelled A to D. Write only the answer next to the letter (A–D) in the ANSWER BOOK. (4)
- [20]

TOTAL SECTION B: 40
GRAND TOTAL: 100

FITTING AND MACHING THEORY N2**FORMULA SHEET**

$$f = ft \times T \times N$$

$$S = \frac{\pi DN}{60}$$

$$S = \pi DN$$

$$\frac{40}{N}$$

$$\frac{N}{9^\circ}$$

$$\text{Set - over} = \frac{D - d}{2} \times \frac{\text{length of workpiece}}{\text{length of taper}}$$

$$\text{Set - over} = \frac{\text{length of workpiece}}{2} \times \text{Ratio}$$

$$\tan \frac{\theta}{2} = \frac{X}{L}$$

$$\text{Leading angle} = 90^\circ - (\text{Helix angle} + \text{clearance angle})$$

$$\text{Following angle} = 90^\circ + (\text{Helix angle} - \text{clearance angle})$$

$$\text{Lead} = \text{No of starts} \times \text{pitch}$$

$$\text{Mean diameter (Dm)} = \text{Outside diameter} - \text{Depth}$$

$$\text{Depth} = \frac{\text{Pitch}}{2}$$

$$L = f \times N \times t$$

$$\tan \theta = \frac{\text{Lead}}{\pi \times D_m}$$