



# higher education & training

---

Department:  
Higher Education and Training  
**REPUBLIC OF SOUTH AFRICA**

## **NATIONAL CERTIFICATE FITTING AND MACHINING THEORY N2**

(11022032)

**7 February 2022 (X-paper)  
09:00–12:00**

**Drawing instruments and nonprogrammable calculators may be used.**

**This question paper consists of 8 pages and 1 formula sheet.**

110Q1E2207

**DEPARTMENT OF HIGHER EDUCATION AND TRAINING**  
**REPUBLIC OF SOUTH AFRICA**  
NATIONAL CERTIFICATE  
FITTING AND MACHINING THEORY N2  
TIME: 3 HOURS  
MARKS: 100

---

**NOTE:** If you answer more than the required number of questions only the required number will be marked. Clearly cross out all work you do not want to be marked.

**INSTRUCTIONS AND INFORMATION**

1. Answer ALL the questions in SECTION A, except for QUESTION 1 where you must answer either QUESTION 1.1 OR QUESTION 1.2.
  2. Answer any TWO questions in SECTION B.
  3. Read all the questions carefully.
  4. Number the answers according to the numbering system used in this question paper.
  5. Start each section on a new page.
  6. Only use a black or blue pen.
  7. Write neatly and legibly.
-

**SECTION A**

**QUESTION 1: OCCUPATIONAL SAFETY**

Answer either QUESTION 1.1 **OR** QUESTION 1.2.

1.1 State FIVE rules for the safe handling and storage of compressed gas cylinders. [5]

**OR**

1.2 State FIVE fire-prevention safety measures to be taken, according to the Minerals Act No. 50 of 1991. [5]

**QUESTION 2: COUPLINGS**

2.1 FIGURE 1 (below) shows a diagram of a coupling.

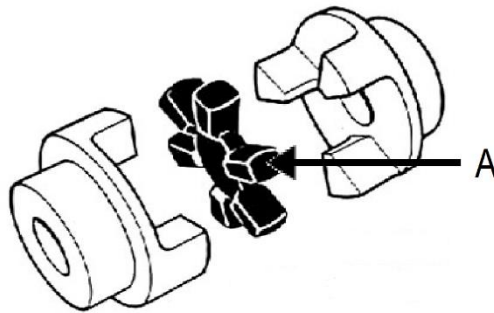

**FIGURE 1**

2.1.1 Name the coupling shown in FIGURE 1 (above)

2.1.2 To which group does this coupling belong?

2.1.3 Name the part labelled A. (3 x 1) (3)

2.2 State the group into which each of the following couplings is classified:

2.2.1 Marine coupling

2.2.2 Resilient coupling

2.2.3 Universal coupling (3 x 1) (3)  
**[6]**

**QUESTION 3: LIMITS AND FITS**

- 3.1 Differentiate between a *hole-basis system* and a *shaft-basis system* in terms of limits and fits. (2)
- 3.2 Name THREE classes of fits.  (3)
- 3.3 Explain each of the following dimensioning terms:
- 3.3.1 Tolerance
- 3.3.2 Basic size
- (2 × 1) (2)  
[7]

**QUESTION 4: BEARINGS**

- 4.1 Name THREE types of rolling elements used in anti-friction bearings. (3)
- 4.2 Explain each of the following terms with regard to the properties of a bearing material:
- 4.2.1 Load capacity
- 4.2.2 Conformability
- (2 × 1) (2)  
[5]

**QUESTION 5: LUBRICATION AND VALVES**

- 5.1 Explain each of the following terms with regard to the properties of lubricants:
- 5.1.1 Viscosity
- 5.1.2 Cohesion
- (2 × 1) (2)
- 5.2 Briefly explain the working principle of a butterfly valve.  (2)
- 5.3 Briefly explain the working principle of a diaphragm valve.  (2)  
[6]

**QUESTION 6: PACKING, STUFFING BOXES, JOINTS AND WATER-PIPE SYSTEMS**

- 6.1 State FOUR advantages of using plastic pipes. (4)
- 6.2 List FOUR methods of joining plastic piping. [9]
- 6.3 Explain the function of a *stuffing box*. (1)

**QUESTION 7: PUMPS**

- 7.1 State ONE function of a pump. (1)
- 7.2 FIGURE 2 (below) shows a type of pump.

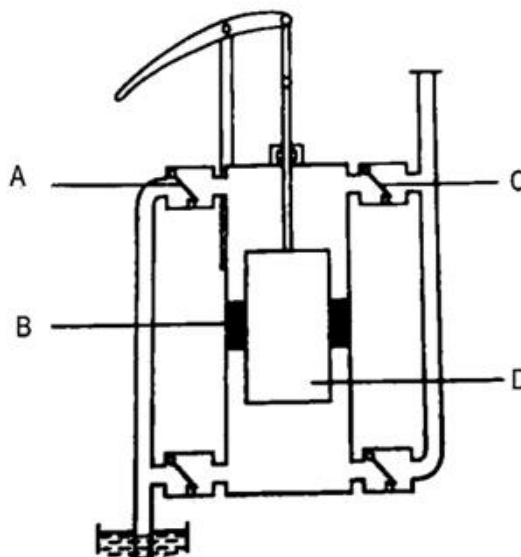

**FIGURE 2**

- 7.2.1 Name the category of pumps into which the pump shown in FIGURE 2 falls [9]
- 7.2.2 Name the parts labelled (A–D). Write only the answer next to the letter (A–D) in the ANSWER BOOK (4)

**QUESTION 8: COMPRESSORS**

Complete the following paragraph by writing only the missing word or words next to the question number (8.1–8.4) in the ANSWER BOOK.

The (8.1) ... stores air at high pressure until it is required for use. It is usually fitted with a (8.2) ... for monitoring air pressure. A (8.3) ... , fitted at the bottom of the air receiver, is used for (8.4) ... (4 × 1)

**QUESTION 9: V-BELTS, CHAIN DRIVES, GEAR DRIVES AND REDUCATION GEARBOXES**

- 9.1 State THREE safety precautions to consider when working with or around chain drives.  (3)
- 9.2 Name THREE types of reduction gearboxes used in the industry. (3)
- 9.3 Give THREE reasons why it is necessary to enclose gear drives in a casing. (3)
- 9.4 Explain each of the following belt-drive terms applicable to V-belts:
- 9.4.1 Arc of contact
- 9.4.2 Belt pitch length
- 9.4.3 Speed ratio
- (3 × 1) (3)
- [12]**
- TOTAL SECTION A: 60**

**SECTION B**

Answer any TWO questions in this section.

**QUESTION 10: PNEUMATICS AND HYDRAULICS**

- 10.1 Name TWO components in a hydraulic system. (2)
- 10.2 Explain the functions of the following hydraulic components:
- 10.2.1 Piping
- 10.2.2 Pump
- 10.2.3 Actuator
- 10.2.4 Reservoir
- (4 × 1) (4)
- 10.3 List the TWO most important factors in the functioning of a hydraulic system and state their SI units.  (4)
- 10.4 Name FOUR types of valves used in a typical hydraulic system. (4)

10.5 FIGURE 3 (below) shows some components that are used in a hydraulic system. Draw a neat, simple circuit diagram of a basic hydraulic system using the components shown in FIGURE 3. ■

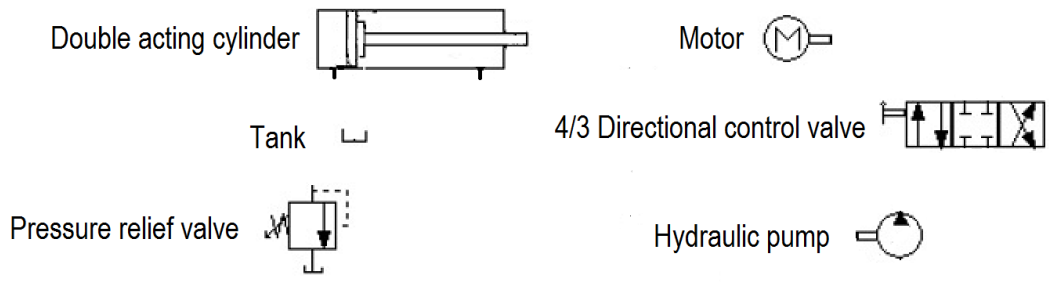

**FIGURE 3**

(6)  
**[20]**

**QUESTION 11: CENTRE LATHE**

- 11.1 What does *CNC* stand for? (1) ■
- 11.2 State FIVE factors to consider when writing a CNC program. (5)
- 11.3 State FOUR advantages of using mandrels. (4)
- 11.4 State any FOUR uses of lathe steadies. (4) ■
- 11.5 A two-start square thread of 10 mm pitch has to be machined on a round shaft with an outside diameter of 70 mm. Assume the clearance angle is 3°.

Calculate: ■

- 11.5.1 The helix angle ( $\theta$ ) of the thread (4)
  - 11.5.2 The lead angle of the cutting tool (1)
  - 11.5.3 The following angle of the cutting tool (1)
- [20]**

**QUESTION 12: MILLING MACHINES AND SURFACE GRINDERS**

12.1 FIGURE 4 (below) shows an accessory used on a milling machine.

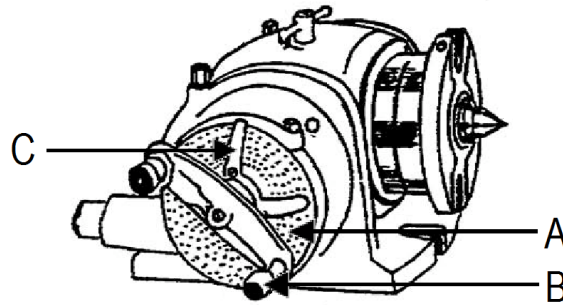

**FIGURE 4**

- 12.1.1 Name the accessory shown in FIGURE 4. (1)
- 12.1.2 State the function of the accessory shown in FIGURE 4. (1)
- 12.1.3 Label the accessory shown in FIGURE 4 by writing the answer next to the letter (A–C) in the ANSWER BOOK. (3 × 1) (3)

12.2 Calculate the required indexing for an angular groove of 65° using a Cincinnati dividing head.

THE CINCINNATI DIVIDING HEAD											
Side 1	24	25	28	30	34	37	38	39	41	42	43
Side 2	46	47	49	51	53	54	57	58	59	62	66

(5)

12.3 Explain each of the following milling terms:

- 12.3.1 Indexing (1)
- 12.3.2 Blind slots (2 × 2) (4)

12.4 Name TWO types of work tables used on surface grinding machines. (2)

12.5 Give FOUR reasons why a work-piece could be scratched when performing surface grinding. (4) [20]

**TOTAL SECTION B: 40**  
**GRAND TOTAL: 100**



(11022032)

## FORMULAE SHEET

1.  $f = f_t \times T \times N$

2.  $S = \frac{\pi DN}{60}$

3.  $S = \pi DN$

4.  $\frac{40}{N}$

5.  $\frac{N}{9^\circ}$

6.  $\frac{D-d}{2} \times \frac{\text{length of workpiece}}{\text{length of taper}}$

7.  $\tan \frac{\theta}{2} = \frac{X}{L}$

8.  $90^\circ - (\text{Helix angle} + \text{clearance angle})$   
 $90^\circ + (\text{Helix angle} - \text{clearance angle})$

9.  $\text{Lead} = \text{number of starts} \times \text{pitch}$